

SECTION A - A
INTEGRAL CURB & GUTTER, DETAIL B

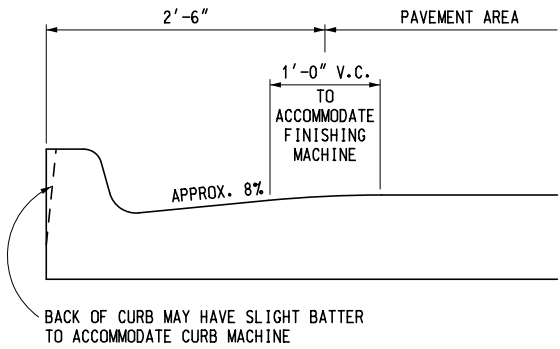

SECTION A - A
INTEGRAL CURB & GUTTER, DETAIL C

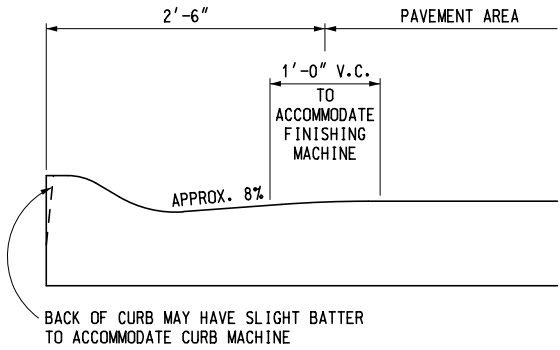

SECTION A - A
INTEGRAL CURB & GUTTER, DETAIL D

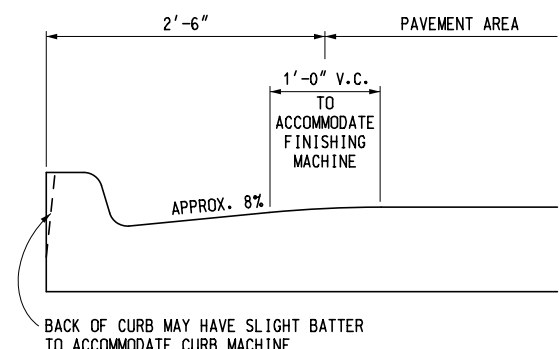

SECTION A - A
INTEGRAL CURB & GUTTER, DETAIL F

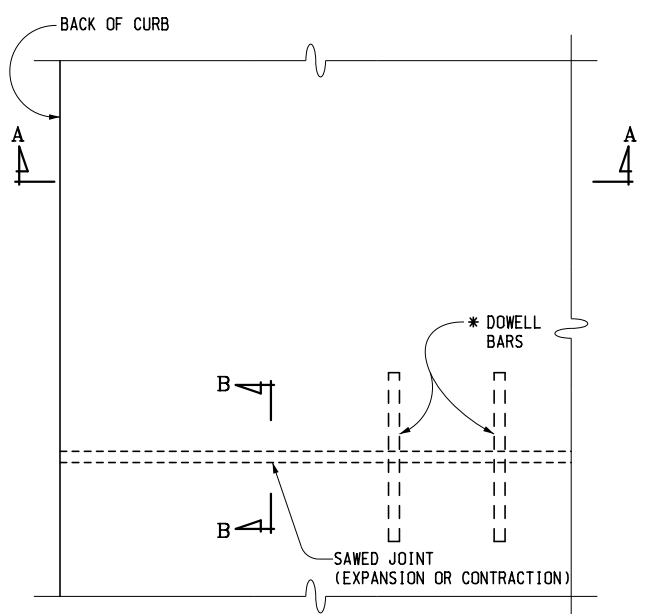

* END DOWELL BARS AT V.C. BEFORE GUTTER PAN.

PLAN AT TRANSVERSE JOINT

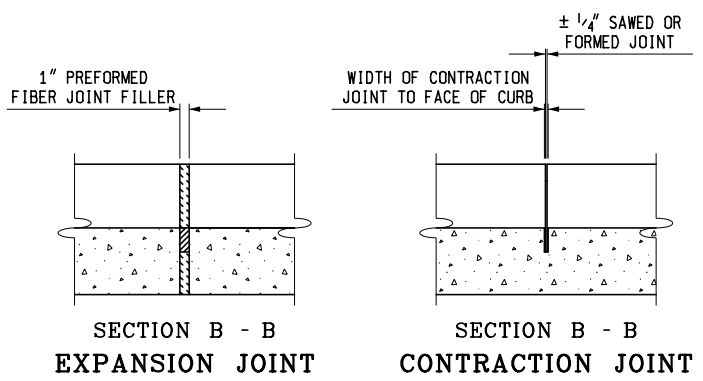

SECTION B - B
EXPANSION JOINT

SECTION B - B
CONTRACTION JOINT

	DEPARTMENT DIRECTOR Kirk T. Stuedle	MICHIGAN DEPARTMENT OF TRANSPORTATION BUREAU OF HIGHWAY DEVELOPMENT STANDARD PLAN FOR	
	APPROVED BY: <i>Randy V. [Signature]</i> DIRECTOR, BUREAU OF FIELD SERVICES	INTEGRAL CURB AND INTEGRAL CURB & GUTTER	
	APPROVED BY: <i>Mark A. Van [Signature]</i> DIRECTOR, BUREAU OF HIGHWAY DEVELOPMENT	1-25-2013 F.H.W.A. APPROVAL	10-22-2012 PLAN DATE
PREPARED BY DESIGN DIVISION			SHEET 1 OF 2
DRAWN BY: <u>B.L.T.</u>			
CHECKED BY: <u>W.K.P.</u>			

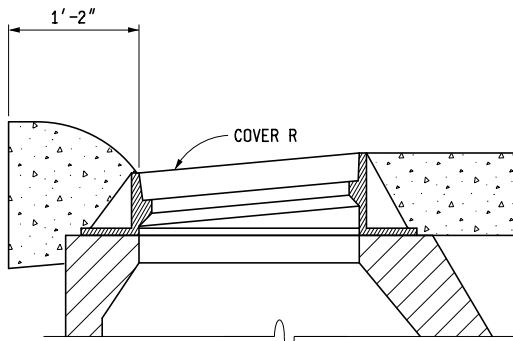

SECTION C - C
INTEGRAL CURB & GUTTER, DETAIL B

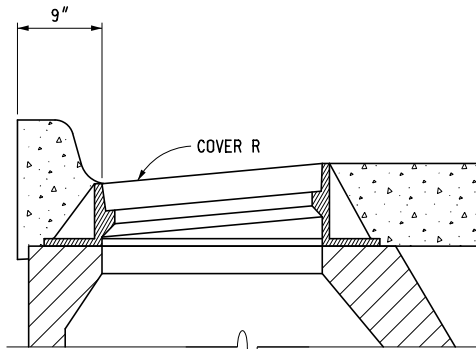

SECTION C - C
INTEGRAL CURB & GUTTER, DETAIL C

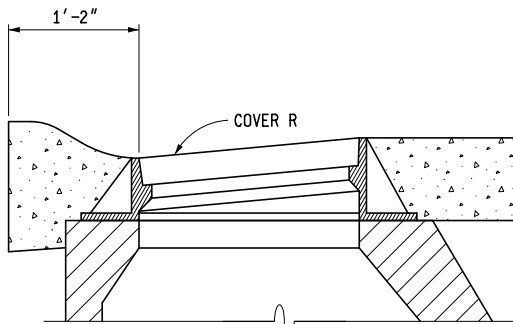

SECTION C - C
INTEGRAL CURB & GUTTER, DETAIL D

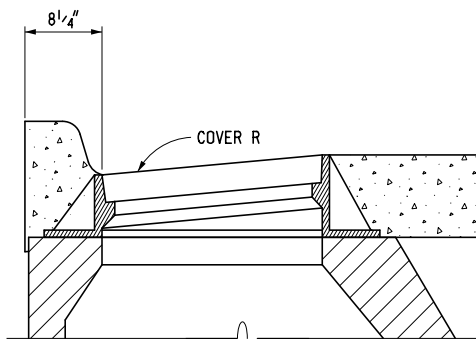

SECTION C - C
INTEGRAL CURB & GUTTER, DETAIL F

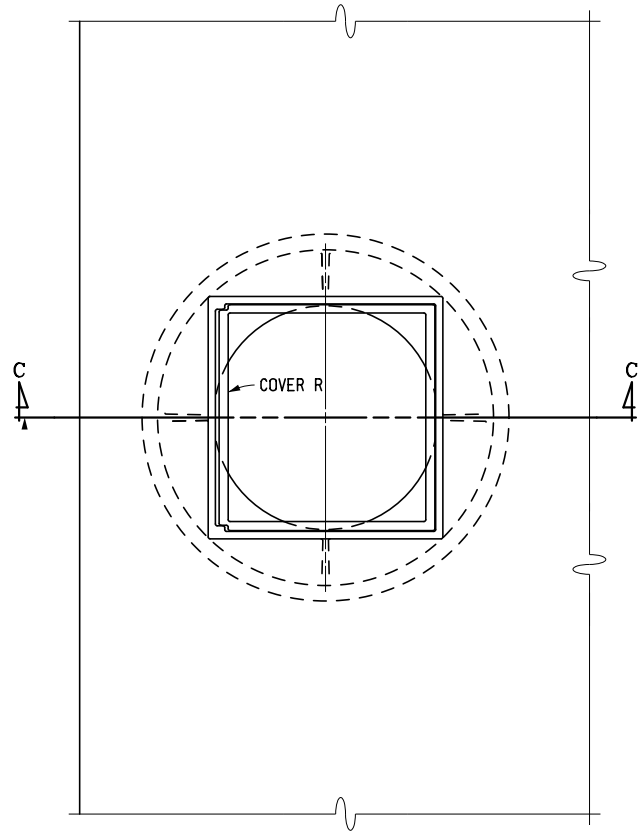

PLAN IN CATCH BASIN AREA
SEE STANDARD PLAN R-37-SERIES FOR REINFORCING DETAILS

NOTES:

DETAILS OF CURB FACES ARE SPECIFIED ON STANDARD PLAN R-30-SERIES.

WHEN THE CURB PORTION IS POURED SEPARATE FROM THE INTEGRAL PAVEMENT AND GUTTER, AND DELAY EXCEEDS 30 MINUTES, EPOXY COATED #4 VERTICAL BARS SPACED AT 1'-0" CENTER TO CENTER SHALL BE USED TO TIE CURB AND UNDERLYING CONCRETE.

AGGREGATE BASE, WHEN SPECIFIED ON TYPICAL CROSS SECTIONS, SHALL EXTEND 2'-0" BEYOND THE BACK OF INTEGRAL CURB AND GUTTER, EVEN IF THE GRADING SECTION MUST BE WIDENED TO DO SO. NO PAYMENT WILL BE MADE FOR THE ADDITIONAL AGGREGATE BASE THAT IS REQUIRED TO CONSTRUCT THE INTEGRAL CURB AND GUTTER ALTERNATE.

TRANSVERSE JOINTS IN THE INTEGRAL CURB SHALL BE AS SPECIFIED ON THIS STANDARD PLAN.

FIBER FILLER USED FOR PAVEMENT EXPANSION JOINTS SHALL EXTEND TO BACK OF CURB.

CATCH BASIN "COVER R" OR OTHER APPROVED COVERS SHALL BE SUBSTITUTED FOR COVERS SPECIFIED ON THE PLANS ONLY WHEN THE INTEGRAL CURB AND GUTTER ALTERNATE IS USED.

MICHIGAN DEPARTMENT OF TRANSPORTATION
BUREAU OF HIGHWAY DEVELOPMENT STANDARD PLAN FOR

INTEGRAL CURB AND
INTEGRAL CURB & GUTTER

1-25-2013
F.H.W.A. APPROVAL

10-22-2012
PLAN DATE

R-31-F

SHEET
2 OF 2